



# ADH<sup>™</sup> -2A COM

## Automatic Air Dehydrator

Part Number: Rack Mounted 17696  
Wall Mounted 17846  
NEMA 17905  
August 1998

### **ENVIRONMENTAL TECHNOLOGY, INC.**

1302 HIGH STREET, SOUTH BEND, IN 46601 USA  
(219) 233-1202 FAX (219) 233-2152  
Toll Free (800) 234-4239 Toll Free FAX (888) 234-4238  
<http://www.networketi.com> email: [helpdesk@networketi.com](mailto:helpdesk@networketi.com)

**DISCLAIMER**

Environmental Technology, Inc. makes no representations or warranties, either expressed or implied, with respect to the contents of this publication or the products that it describes, and specifically disclaims any implied warranties of merchantability or fitness for any particular purpose. Environmental Technology, Inc. reserves the right to revise this publication, and to make changes and improvements to the products described in this publication, without the obligation of Environmental Technology, Inc. to notify any person or organization of such revisions, changes or improvements.

Third edition	August 1998
Second edition	September 1996
First edition	July 1996

Copyright ©1996, 1998 by Environmental Technology, Inc.

**Printed in USA**

All rights reserved. No part of this manual may be reproduced or transmitted in any form or by any means, electronic or mechanical, including photocopying and recording, for any purpose without the express written consent of Environmental Technology, Inc.

**Abnormal Odor or Smoke**

In the event of smoke or an abnormal odor, immediately interrupt power to the ADH-2A COM with the POWER switch at the rear of the unit, unplug the unit, or trip the circuit breaker controlling the outlet.

**Lethal Voltages Present**

There are lethal voltages present inside the case of the ADH-2A COM. Service should be performed by qualified personnel only. There are no user serviceable components inside the chassis.

**Pneumatics**

The air pump in the ADH-2A COM is capable of generating as much as 8 psig (55kPa). Proper safety practice requires treating all pneumatic components with care. Always vent the system to atmospheric pressure before servicing pneumatic components.

**Rack Mounting**

Before rack mounting the ADH-2A COM ensure that rack is stable. Verify adequate air flow and power supply capacity is available to the unit. Ensure that ADH-2A COM maximum operating temperature of 130°F(55°C) will not be compromised by other components in rack. Ensure reliable earthing of ADH-2A COM.

**Environmental Technology, Inc.**

# Contents

<b>Introduction .....</b>	<b>9</b>
Purpose .....	9
Description .....	9
<b>Installation .....</b>	<b>10</b>
Unpacking/Packing .....	10
Inventory List .....	10
Initial Inspection .....	11
Location .....	12
Principal Considerations .....	13
Power Connection .....	13
Pneumatic Connection .....	13
<b>Communications .....</b>	<b>14</b>
Address Jumper Assignments .....	14
Example Address Calculation .....	14
Special Jumper Settings .....	14
<b>Controls .....</b>	<b>15</b>
<b>Indicators.....</b>	<b>15</b>
<b>Operating Procedures .....</b>	<b>16</b>
Automatic Operation .....	16
<b>Communications Format &amp; Protocol .....</b>	<b>16</b>
Overview .....	16
Standard Mode Command Format.....	16
Standard Mode Response to a Command .....	17
Checksum Calculation .....	17
Terminal Mode Command Format .....	17
Terminal Mode Response Format .....	17
Command Summary .....	17
Example Communication Session .....	19
Alarm Relays .....	19
<b>Emergency Procedures.....</b>	<b>20</b>
Abnormal Smoke or Odor .....	20
Ruptured feed window .....	20
<b>Technical Description .....</b>	<b>20</b>
Electronic .....	20
Pneumatic .....	20
Theory of Operation.....	21
<b>Maintenance .....</b>	<b>21</b>

Preventive Maintenance .....	21
Corrective Maintenance .....	21
Returns and Replacement Parts Purchases .....	22
Troubleshooting .....	23
<b>Appendix A. Specifications .....</b>	<b>27</b>
<b>Appendix B. Alarms, Warnings and Status .....</b>	<b>28</b>
Display Meaning .....	28
Status Interpretation .....	28
<b>Appendix C. Master/Slave Configuration.....</b>	<b>29</b>
Purpose .....	29
Description .....	29
Remote Terminal Communications .....	29
<b>APPENDIX D. NEMA Configuration .....</b>	<b>31</b>
Purpose .....	31
Description .....	31
Installation .....	31
Input Voltage .....	32



**Environmental Technology, Inc.**

# Introduction

## Purpose

Unpressurized dielectric transmission lines allow the entry of moist ambient air through leaking seals, penetrations and cracks. When the line passes from one environment to another (such as when entering a shelter from the antenna outside) or when there is a change in existing environmental conditions (such as a weather front, or nightfall) the pressure and/or temperature changes in the air will result in the collection of water. This is normally the result of the ambient temperature dropping below the dew point. Water in transmission lines causes corrosion, voltage arcing and increased VSWR. These conditions reduce system performance.

The ADH-2A COM Automatic Dehydrator prevents the accumulation of moisture in dielectric lines by maintaining the pressure and humidity of the air in the line. Supplying low pressure dry air, the ADH-2A COM keeps waveguides, air dielectric coaxial cable and other related components used in earth station and terrestrial UHF and microwave communication systems dry.

## Description

The ADH-2A COM is an automatic air dehydrator. Air is pressurized by a diaphragm pump and then dehydrated by passing it through an absorption unit containing a drying agent. The dried air is then delivered to the communications equipment through a connection on the rear panel. The moisture is removed from the absorption units by heat. The standard unit provides dry air at 0.5 psig (34.5 mbar) and is capable of delivering 14 cubic feet of air per hour (6.7 l/m). Optional pressures are 3.0 and 6.0 psig (207 and 414 mbar).

Two absorption units are employed to provide a continuous supply of dried air. One unit is active while the other is in standby or being regenerated. Under normal conditions, the maximum dew point of the air is  $-40^{\circ}\text{C}$  and nominally  $-70^{\circ}\text{C}$ . The ADH-2A COM will operate on one of the absorption units until that unit is fully saturated, or for up to 200 hours, whichever condition is reached first. When this occurs, the standby absorption unit is brought into service and the used unit is regenerated. The absorption unit being regenerated is heated internally with a resistance heater until a temperature is attained which will convert all absorbed water to steam. The resulting vapor is purged by pumping ambient air through the absorption unit and collecting the water in an evaporator where it is again heated and driven off as water vapor. No drain line or special ventilation is needed with this unit.

The ADH-2A COM is controlled by a microprocessor. All of the electronic components in this unit reside on two circuit boards. The main processor is located on the Front Panel Board which also contains a pressure transducer, display elements and indicators, voltage regulators and communications components. The alarm relay is located on the Interface Board along with the hardware drivers for the electromechanical components. Power is supplied to the system via a transformer and a full wave rectifier. A large, red display shows outlet pressure or user selected status and diagnostic information. Three LEDs give instant visual status. An RS-422 asynchronous communications facility is

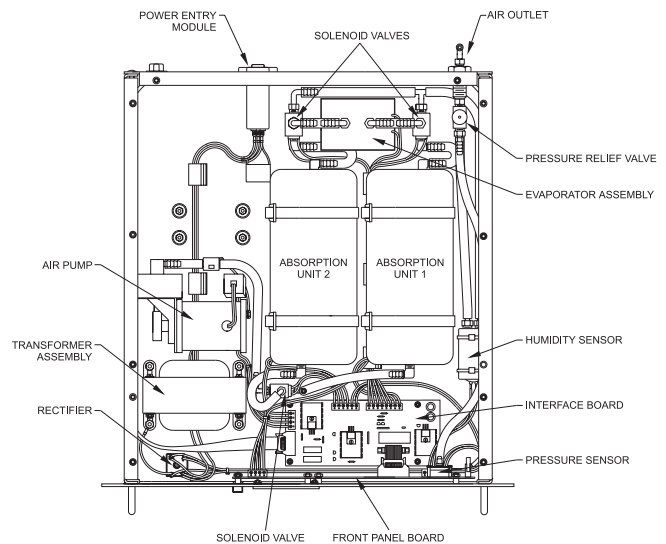

Figure 1. ADH-2A COM components

## Environmental Technology, Inc.

provided which allows remote monitoring. The ADH-2A COM also contains an alarm relay which is energized when power is applied to the unit and de-energized when error conditions are encountered.

Physically, the ADH-2A COM occupies three spaces of a standard relay rack. No other peripheral equipment is required. The chassis is constructed of heavy gauge aluminum alloy. All surfaces are protected by anodization or a baked finish using the latest powder coating technology.

## Installation

### Unpacking/Packing

Immediately inspect the shipping container and packing material for damage. Unpack the ADH-2A COM, taking care not to damage the cushioning materials. Save the shipping container and related materials until normal operation has been established. If the unit must be returned, take care to ensure that it is repackaged as it was received.

### Inventory List

The ADH-2A COM package should contain the following:

#### Rack Mount

Qty.	Part Number	Description
1	17696	ADH-2A COM Automatic Air Dehydrator, Rack Mount
1	17697	ADH-2A COM Instruction Manual
1	17855	Accessory Package containing a power cord and power entry module.

#### Wall Mount

Qty.	Part Number	Description
1	17846	ADH-2A COM Automatic Air Dehydrator, Wall Mount
1	17697	ADH-2A COM Instruction Manual
1	17855	Accessory Package containing a power cord and power entry module.

#### NEMA

Qty.	Part Number	Description
1	17905	ADH-2A COM Automatic Air Dehydrator, NEMA
1	17697	ADH-2A COM Instruction Manual

Additional equipment required for installation:

- Tubing and Fittings. The ADH-2A COM comes equipped with a 1/4" hose barb fitting which accepts 1/4" I.D. flexible tubing. 1/8" NPT female is available by removing the hose barb fitting.
- Flat-head screwdriver

**Initial Inspection**

Inspect the ADH-2A COM for electrical and mechanical damage. If any of the following problems are found contact the Customer Service Department.

- **Contents incomplete or incorrect**
- **Internal or external mechanical damage**
- **Defective operation**

Customer service is available between 8:00 a.m. and 5:00 p.m. EST (UTC minus 5 hours) at 219-233-1202 or 800-234-4239. In the event of shipping damage, keep the packing materials for inspection by the carrier. Normally, Environmental Technology, Inc. will repair or replace the ADH-2A COM without waiting for the claims settlement.

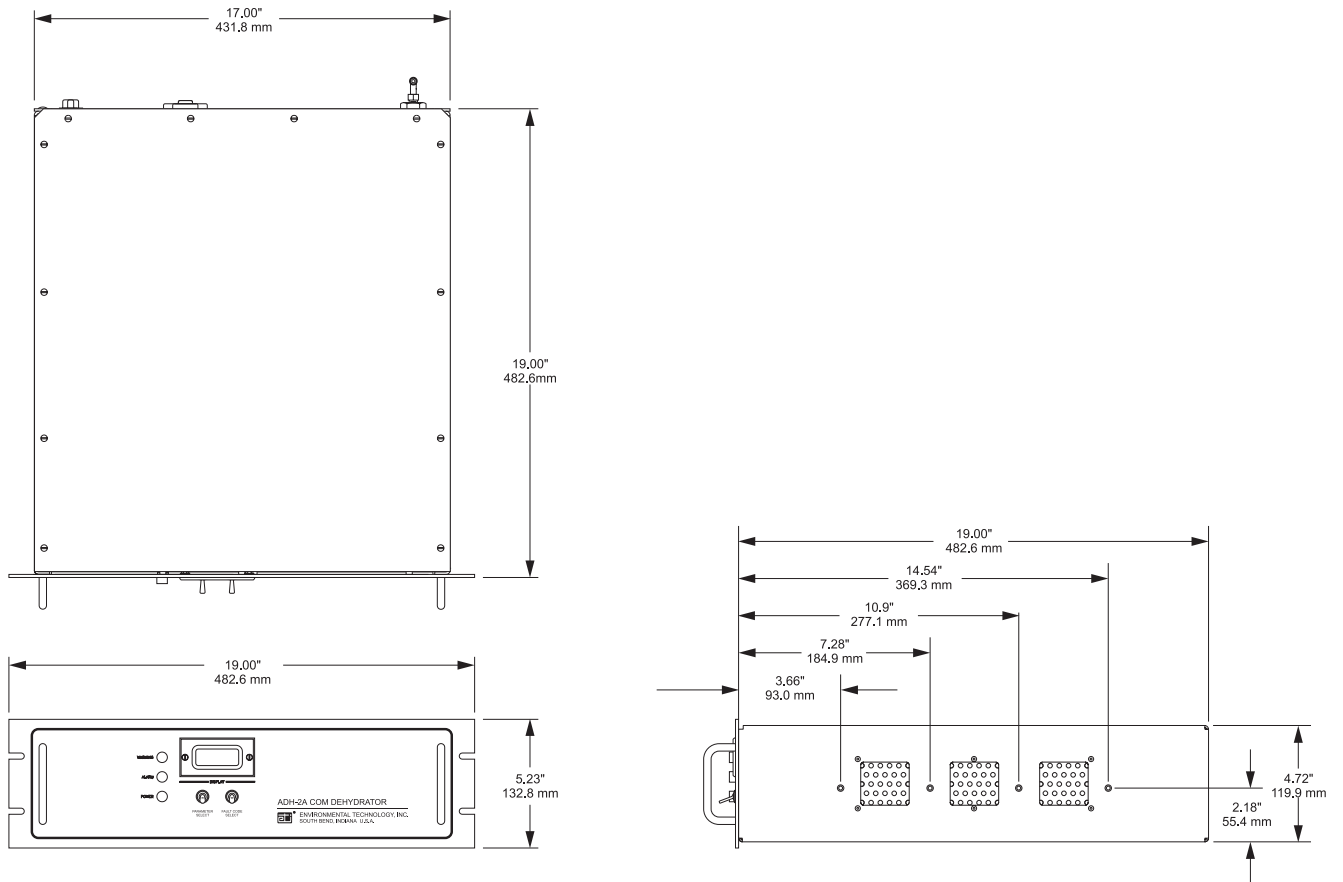
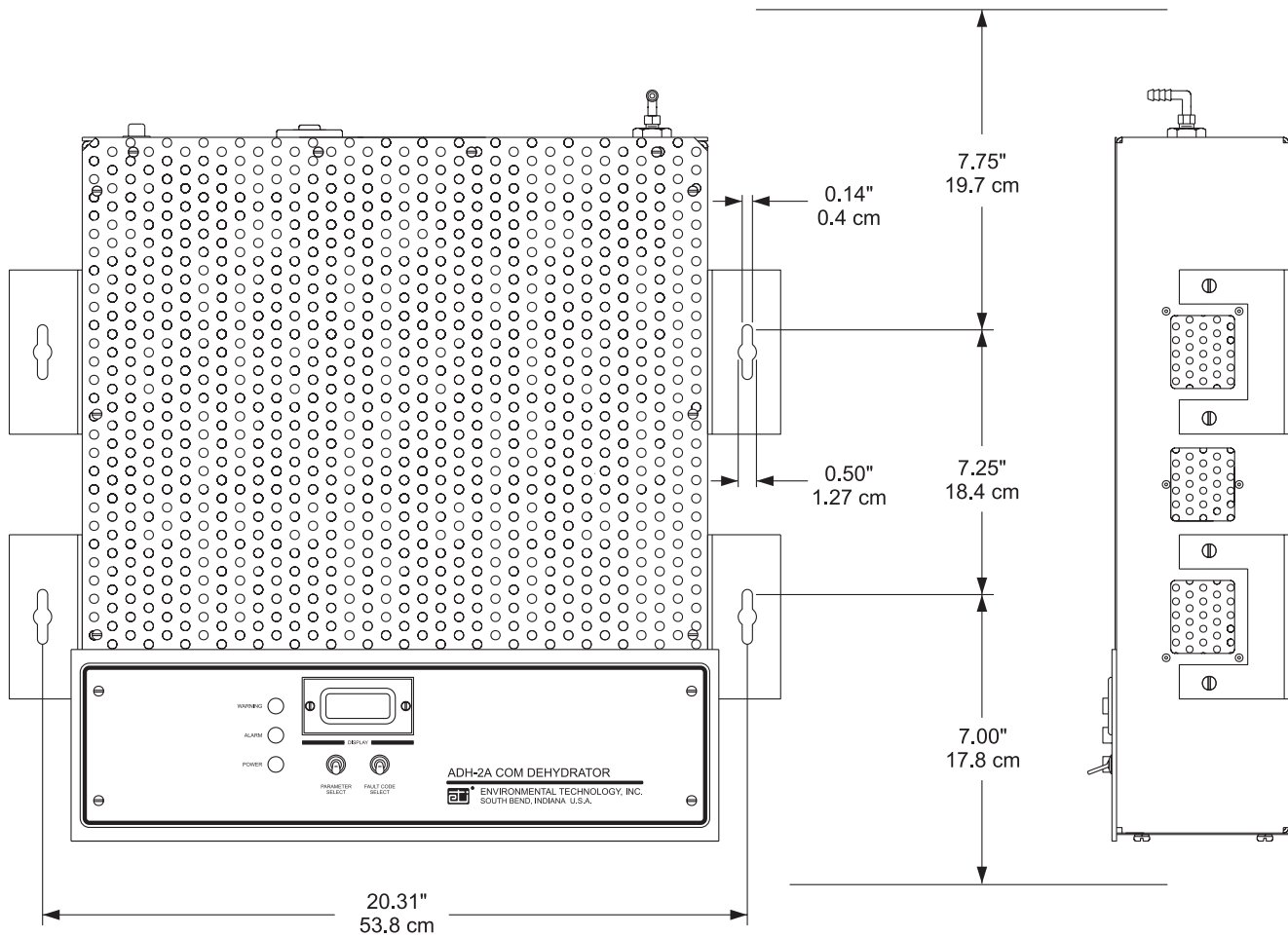

Figure 2. Rack mounting dimensions



*Figure 3. Wall mounting dimensions*

**Location**

The rack mounted ADH-2A COM requires a relay rack panel space of 19 inches by 5-1/4 inches (see Figure 2). Since the ADH-2A COM seldom requires operator attention, a location in the lower portion or extreme upper portion of the relay rack should be considered. The side panels of the chassis contain tapped holes (#8-32) to facilitate installation. Use chassis slides or support channels mounted on the inside of the relay rack; the front panel alone is not sufficient to support this unit.

The wall mount version requires an area of approximately 22 inches high by 22 inches wide (56 cm by 56 cm) and will project almost 6 inches (15 cm) from the wall. Plan your installation so that the ADH-3COM will not interfere with normal traffic patterns at your site. Ensure the wall mounted unit has sufficient clearance above the connection panel to facilitate access to the power, communications and pneumatic interfaces. The mounting brackets will accommodate fasteners up to 1/4 inch (6.3 mm) in diameter. The choice of anchors and companion hardware should be appropriate for the mounting surface. At least four anchors should be used and each should be able of supporting at least 15 pounds (7 kg). If more than four anchors are used, it is recommended that the combined load capacity be at least 60 pounds (30 kg). The location of the mounting points is shown in Figure 3. When installed the front panel will be at the bottom of the unit. The power entry module, air outlet, alarm relay port and communication port will be located at the top of the unit.

## Principal Considerations

The ADH-2A COM works best supplying dry air in a flowing system, where the dehydrator completely replaces the air on a regular, albeit leisurely, basis. Consequently, the equipment being supplied dry air should be *slightly leaky*. For a waveguide, this is best accomplished by slightly opening a purge valve at the window end of the system. Likewise, air dielectric coaxial cable should be equipped with a valve at the far end which can be set to allow a small leak. Many systems will have sufficient normal leakage that such actions will be unnecessary. The life expectancy of the air pumps is greatest with a duty cycle between 1 and 5%.

The ADH-2A COM also has check valves in the air path. A tightly sealed system may experience a pressure increase with a rise in ambient temperature. The unit has no way to reduce such a pressure buildup.

## Power Connection

The ADH-2A COM requires a standard outlet (North American: NEMA 5-15R) no further than 6' (1.8 m) from the power entry module. The power entry module is located at the rear of unit on rack mounted ADH-2A COM's, and at the top of the unit on wall mounted units. The main power switch is incorporated in the power entry module. The power cord contains a ground lead, but it is recommended that the unit be connected to true earth ground using the lug next to the power entry module. Insert the fuse holder into power entry module with triangle of supply voltage required on fuse holder aligned with the triangle on the power entry module. Verify that the proper voltage has been selected at the power entry unit before applying power to the unit. If the supply voltage must be changed, verify that the power switch is in the off position and the ADH-2A COM is disconnected from any power source. Remove the fuse holder from the power entry module using a small flat-head screwdriver. Turn the fuse holder so that the triangle on the power entry module is aligned with the triangle on the fuse holder for required supply voltage and insert it back into the power entry module.

## Pneumatic Connection

This unit is supplied with a 1/4" barbed male fitting. Slip the supply tubing over the outlet barb engaging all the ridges. The fit should be tight enough that a clamp or cable tie is not required although its use is recommended. If required, the barbed fitting may be removed to make use of a 1/8" NPT female fitting. Special accessories including distribution manifolds, a variety of pressure fittings and tubing are available from Customer Service.

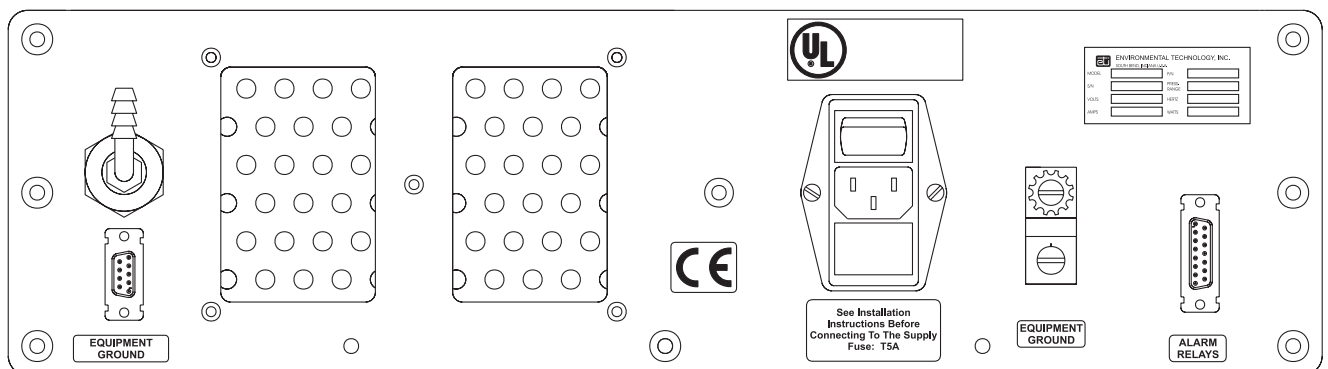

Figure 4. Back panel connections

**Environmental Technology, Inc.**

Pin	Description	Comments
1	Shield Ground	
2	Receive Ready	Tied to +5 volts via a 4.7K resistor internally
3	Receive +	Note: Also typically referred to as "R+" or "RB"
4	Transmit +	Note: Also typically referred to as "T+" or "TB"
5	Signal Ground	
6	Transmit -	Note: Also typically referred to as "T-" or "TA"
7	Request to Send	Pin 7 (RTS) is tied internally to pin 8 (CTS)
8	Clear to Send	Pin 8 (CTS) is tied internally to pin 7 (RTS)
9	Receive -	Note: Also typically referred to as "R-" or "RA"

Table 1. Communication connector pin assignments

## Communications

The ADH-2A COM conforms to the EIA RS-422 standard. The RS-422 standard permits a maximum of ten devices on a run of cable of up to 4000ft.(1219.2 meters) in length. The ADH-2A COM interfaces through a DB-9 male connector (see Table 1).

### Address Jumper Assignments

The front panel board has jumpers that provide configuration information to the firmware. These jumpers can be set at the factory based on customer requirements and hardware configuration. The initial address set at the factory is 30h. This address may be changed by the customer. Jumpers J5-7 through J5-12 (see Figure 4) located on the front panel board, configure the ADH-2A COM's network address. The address is set in binary. Pin 12 is the least significant bit and pin 7 is the most significant bit. See Table 2 for the values of each jumper in hex. The address is calculated by adding the values of the set jumpers. The sum of the previous calculation is then added to the base address of 30 hex. This is the final address you will use to communicate with the unit. There are three exceptions to this rule. The exceptions are covered in the Special Jumper Settings listed below.

### Example Address Calculation

Suppose jumpers J5-12, J5-11, and J5- 8 are set. That is, the pins are connected together. The address is calculated by adding the base (30 hex) to the values from Table 2.

Final Address = 30 + 10 + 2 + 1 = 43 Hex

When accessing this ADH-2A COM the above address is the one used.

Pin Set	Jumper On	Jumper Off
1	Factory use only	Factory use only
2	Factory use only	Factory use only
3	Factory use only	Factory use only
4	Factory use only	Factory use only
5	Metric Display	English Display
6	1200 baud	9600 baud
7 (MSB)	AD5 = 20h	AD5 = 0
8	AD4 = 10h	AD4 = 0
9	AD3 = 8h	AD3 = 0
10	AD2 = 4h	AD2 = 0
11	AD1 = 2h	AD1 = 0
12 (LSB)	AD0 = 1h	AD0 = 0

Table 2. Jumper block 5 jumper definitions

### Special Jumper Settings

The address 50, 51, and 52 hex places the ADH-2A COM into Terminal mode. When in this mode the unit will respond to all requests in straight ASCII. The difference in the addresses is that they have different end-of-line (EOL) characters. Please refer to the Terminal Mode Response Format listing for a complete description.

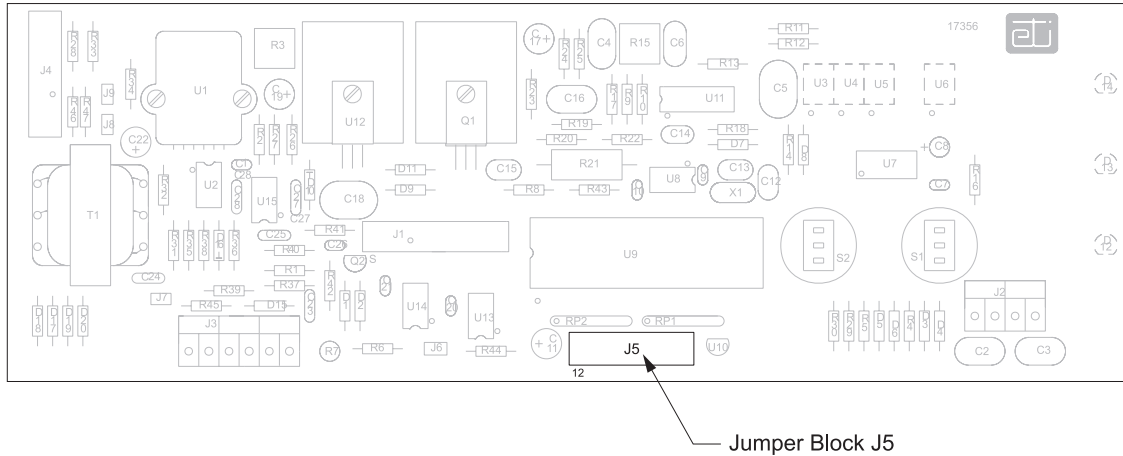

Figure 5. Front Panel Board

# Operation

## Controls

This unit has three switches: one power switch and two front panel switches. The power switch is located at the rear of the rack mounted unit, the top of the wall mounted unit. The two front panel switches allow the user to display the operating parameters and the unit status. The **Parameter Select** switch cycles through the operating parameters. The **Fault Code Select** switch cycles through the fault codes. The front panel switches are usable with the ADH-2A COM configured for remote operation (terminal mode or master/slave).

## Indicators

The front panel display is composed of four digits that show parameter and status information. A timer is associated with the display to prolong its life. When activated by the front panel switches, the display will remain active for ten minutes and then will go blank. Depressing either switch will restore the display.

Three front panel LED's provide visual indicators for power, warning and alarm conditions. The **Power** LED illuminates as long as the unit is energized. The **Warning** LED illuminates when temporary conditions are detected. Conditions that may generate a warning include high duty cycle (excessive leak in system), high or low ambient temperature, and low line voltage. The **Alarm** LED illuminates when a condition is encountered which may prevent the ADH-2A COM from delivering dry air. The Warning and Alarm indications will clear automatically when the cause of the problem has been corrected.

## Operating Procedures

### Automatic Operation

The ADH-2A COM will commence automatic operation when power is applied. After the initial installation, we recommend monitoring the unit's duty cycle during the first few days of operation and monthly thereafter. The unit must cycle several times before the duty cycle can be established. Again, the system should be configured so that a 1 to 5% duty cycle ( as displayed at the front panel ) is achieved.

The operating parameters and status of the absorption units can be displayed by depressing the **Parameter Select** switch. The value displayed will be a letter and a numerical value or two letters (*see Table 3*).

**Note:** *Duty Cycle and Flow Rate will display dashes until compressor runs twice.*

Depressing the **Fault Code Select** switch will cause any system errors to be displayed. Toggle this switch several times to ensure that all information is displayed as several errors may occur simultaneously depending upon the problem.

Parameter	Display
Pressure	P x.xx psig or P xx.x millibars (standard pressure option) P xx.x psig or P xxx millibars (high pressure options)
Ambient temperature	A xxx °F or °C
Absorption unit status	S xx, Unit 1 and Unit 2 respectively
Duty cycle	d xxx%
Flow rate	F xxx thousandths of a cu. ft./min. or F xxx l/min.
Accumulated compressor time	C xxx 10's hours

Table 3. Operating parameters

## Communications Format & Protocol

### Overview

The ADH-2A COM communicates at 1200 or 9600 baud using seven data bits, one stop bit, and even parity. There are two modes of operation: standard mode and terminal mode. Standard mode complies with the S-A (Scientific Atlanta) protocol. In terminal mode the unit responds in straight ASCII. Terminal mode should be used when the unit is accessed by a dumb terminal. The mode and baud rate are selectable by jumpers on the front panel board.

### Standard Mode Command Format

A valid command in the standard mode (S-A Compliant) must consist of the following: The first character is STX (2 Hex) and is followed by the remote address. Next, the command you wish to execute and the associated data bytes are transmitted. ETX (3 Hex), and the checksum are then sent to conclude the transmission.

## Standard Mode Response to a Command

The response format of the unit is identical to the command format except for the first character. If the command was understood, an ACK (06 Hex) will replace the STX character. If the command was not understood or cannot be acted upon, the response will begin with an NAK (15 Hex) and the data bytes will not be returned; only the NAK, address, command, ETX, and the checksum will be sent.

## Checksum Calculation

The checksum is a bitwise exclusive-or of all the characters in the stream. This includes the STX and the ETX characters.

## Terminal Mode Command Format

When the unit is placed in terminal mode the only valid command is the carriage return (0D Hex). This requests the unit for the status.

## Terminal Mode Response Format

Terminal Mode is straight ASCII. The EOL depends on the jumper settings. If the jumpers are set for address 50 Hex, the delimiter will be a carriage return (0D Hex). If the address is 51, the delimiter will be a Line feed (0A Hex). The address 52 selects the combination carriage return/linefeed as the delimiter.

## Command Summary

### **Command 30**

This command returns the device ID and version of the unit. A typical response would look like “AD2A31.” This means the unit is an ADH-2A COM and the version is 3.1.

### **Command 31**

This command returns the full system status. The response will be an array of data bytes that represent the system status (*see Table 4*).

### **Command 37**

This command instructs a unit to go into standby mode.

*Caution: The unit will not supply air in this mode.*

### **Command 38**

This command instructs a unit to go into active mode. This is the typical mode of operation.

**Environmental Technology, Inc.**

Byte#	Char	Dec	Hex	Description
0	E	69	45	English low pressure (.05 psi)
	F	70	46	English high pressure (3 psi)
	G	71	47	English high pressure (6 psi)
	M	77	4d	Metric low pressure (3.5 mbars)
	N	78	4e	Metric high pressure (207 mbars)
	O	79	4f	Metric high pressure ( 413 mbars)
1-3	-	48-57	30-39	Low pressure English : 1.23 psi High pressure English: 12.3 psi Low pressure Metric : 12.3 mbars High pressure Metric : 123. mbars
4	+,-	43,45	2b,2d	Positive or Negative temp indicator
5-7	-	48-57	30-39	Temperature in degrees F or C
8	I	73	49	Absorption Unit #1 Idle
	U	85	55	Absorption Unit #1 In use
	R	82	52	Absorption Unit #1 Regenerating
	F	70	46	Absorption Unit #1 Full
	D	68	44	Absorption Unit #1 Dead
	L	76	4c	System Leaky
	S	83	53	System Standby
9	I	73	49	Absorption Unit #2 Idle
	U	85	55	Absorption Unit #2 In use
	R	82	52	Absorption Unit #2 Regenerating
	F	70	46	Absorption Unit #2 Full
	D	68	44	Absorption Unit #2 Dead
	L	76	4c	System Leaky
	S	83	53	System Standby
10-12	-	48-57	30-39	Duty Cycle in percent
13-15	-	48-57	30-39	Flow Rate : .13 14 15 in ft^3/min Flow Rate : 13.14 15 liters/min Note, replaced with “—” if unavailable
16	+,-	43,45	2b,2d	Low pressure alarm :+,- = True, False
17	+,-	43,45	2b,2d	High pressure alarm :+,- = True, False
18	+,-	43,45	2b,2d	Leaky system warning :+,- = True, False
19	+,-	43,45	2b,2d	High temp warning :+,- = True, False
20	+,-	43,45	2b,2d	Low temp warning :+,- = True, False
21	+,-	43,45	2b,2d	Low Line voltage warning :+,- = True, False
22	+,-	43,45	2b,2d	AU #1 won't heat alarm :+,- = True, False
23	+,-	43,45	2b,2d	AU #1 won't cool alarm :+,- = True, False
24	+,-	43,45	2b,2d	AU #2 won't heat alarm :+,- = True, False
25	+,-	43,45	2b,2d	AU #2 won't cool alarm :+,- = True, False
26	+,-	43,45	2b,2d	Leaky shutdown alarm :+,- = True, False
27	+,-	43,45	2b,2d	Dew point alarm :+,- = True, False
28	+,-	43,45	2b,2d	Change Compressor warning:+,- = True, False
29	W," "	87,32	57,20	W = Warning present, Space = No warning
30	A," "	65,32	41,20	A = Alarm present, Space = No Alarm

*Table 4. Communication summary*

**Example Communication Session**

Suppose we wish to communicate with a ADH-2A COM that has no address jumpers set, making the user selected address 0. Then we add 30 hex to this number (remember, 30 hex gets added to every address). This makes for a final address of 30 hex for this ADH-2A COM. Now, suppose we wish to retrieve the units status. The command we use is 31. The following is the string of bytes that must be sent:

*02, 30, 31, 00*

The bytes, in order, are STX, ADDRESS, COMMAND, ETX, CHECKSUM.

*06, 30, 31, 45, 30, 31, 33, 2b, 30, 36, 30, 55, 52, 30, 31, 30, 30, 31, 35, 2d, 2d, 2d, 2d, 2d, 2b, 2d, 2d, 2d, 2d, 2d, 2d, 2d, 57, 20, 03, 30*

This message decodes as follows:

- 06, 30, 31** = STX, ADDRESS, COMMAND
- 45, 30, 31, 33** = E013 = English, 0.13 psig. The decimal point is assumed and its location is determined by pressure and display options.
- 2b, 30, 36, 30** = +060 = +60°F
- 55, 52** = UR = Absorption unit #1 in use, absorption unit #2 regenerating.
- 30, 31, 30** = 010 = 10% duty cycle.
- 30, 31, 35** = 015 = 0.015 cfm flow rate.
- 2d, 2d, 2d, 2d, 2d, 2b, 2d, 2d, 2d, 2d, 2d, 2d, 2d, 57, 20** = "-----+-----W " = Indicates that Warning 6 (low line voltage) has been issued and no alarms are present.
- 03, 30** = ETX, CHECKSUM

**Note:** The 13 data fields following the flow rate field correspond to the alarms and warnings shown in Appendix B.

**Alarm Relays**

Two alarm relays are available through a DB-15 female connector located on the rear of the ADH-2A COM. Refer to Table 5 for pinout definition. Alarm relay 1 is a summary alarm and close when any of the following six conditions are met:

1. High pressure
2. Absorption unit heating failure
3. Absorption unit overheating or fail to cool
4. Excessive leakage
5. Dew point
6. Low pressure

Alarm Relay 2 close for low pressure. Both relays close at power off.

Pin	Description
1	Relay 1 Normally open
2	Relay 1 Normally closed
3	Relay 2 Normally open
4	Relay 2 Common
5	Relay 2 Normally closed
6	Not used
7	Not used
8	Not used
9	Relay 1 Common
10	Not used
11	Not used
12	Not used
13	Not used
14	Not used
15	Not used

Table 5. Alarm relay connector pin assignments

## **Emergency Procedures**

### **Abnormal Smoke or Odor**

Immediately interrupt the power to the unit by toggling the power switch on the back panel, unplugging the unit, or by tripping the breaker on the power circuit. The transformer contains fuse links that operate in the event of excessive current or temperature.

### **Ruptured feed window**

A ruptured feed window makes it impossible to maintain pressure in the system. In addition, this condition makes it possible for water to flow into the dehydrator in the event of heavy rain. If this problem occurs, immediately remove power from the unit. The outlet solenoids will go to the closed position, and prevent backflow into the unit.

The ADH-2A COM will stop trying to pressurize a system if the compressor runs for 4 hours continuously. The outlet solenoids will be closed. To restore normal operation, momentarily interrupt power to the unit.

## **Technical Description**

### **Electronic**

The power supply in the ADH-2A COM consists of the line cord, the power switch, the transformer, a full wave rectifier and several voltage regulators. The transformer is constructed with fuses in the primary windings.

The output of the full wave rectifier (+24 VDC) is used by the air pumps, the solenoids, and the heaters in the absorption units. The regulated +12 VDC provides power for the pressure transducer and several of the amplifiers. Regulated +5 VDC is used by most of the integrated circuits. A reference voltage of +3.6 V is supplied by the last regulator and is used in comparator circuits.

The main processor consists of a single integrated circuit that requires almost no support circuitry. The device carries the control software in onboard ROM, it has built in analog-to-digital conversion and it debounces the input from the front panel switches. The front panel indicators and the display are controlled by a device driver which receives display information from the processor. An EEROM is used to accumulate compressor run time. The secondary processor controls the electromagnetic components via solid state devices (FET's). The communications port is driven by line transceivers.

### **Pneumatic**

The pneumatic system from the pump to the unit's outlet operates at the system pressure. The air pump is an oilless, diaphragm type compressor. Air is drawn into the pump, compressed, and delivered to the system. The solenoid at the pump outlet acts as a check valve to ensure that pressure is maintained even in the event power is lost. The active absorption unit is selected by a solenoid air valve. After passing through the absorption unit, another solenoid routes the air to the humidity sensor. From the humidity sensor, the dried air is then fed to the outlet. The solenoids at the outlet of the absorption units divert the air to the evaporation unit during regeneration. If power to unit is interrupted, the outlet solenoids will go to their normally closed

position and will also act as check valves to maintain system pressure. The relief valve will operate at 1.8 psig (124 mbar) for standard pressure. Other relief valves are supplied for higher pressure operation.

## **Theory of Operation**

The ADH-2A COM consists of two control loops: the first loop controls system pressure and the second loop controls regeneration. The pressure control loop is composed of the air pumps, the pressure transducer and the main microprocessor. The outlet pressure is monitored. When the pressure drops to the low limit, the air pumps are started and system pressure increases until the processor obtains a high limit reading from the transducer. At this point the pumps are stopped and the loop is complete.

The running time for the compressor is accumulated and stored in the EEROM. When 8,000 hours have been recorded, a Warning (#13) is issued. The time each absorption unit is placed in service is also recorded and regeneration will be initiated when 200 hours (8.3 days) have elapsed if the humidity sensor has not detected moisture. If the humidity sensor detects moisture in the output stream and it exceeds the high limit, then regeneration is initiated.

Regeneration is controlled by the main processor. A sensor monitors the temperature of the absorption unit. The absorption unit is heated until the desired temperature is obtained. The absorption unit and its contents are allowed to soak at this temperature for a period. The absorption unit is then purged by pressurized air. The regeneration cycle takes about 2 hours. If the absorption unit fails to reach the desired temperature, it is declared dead and an error is issued. The absorption unit is allowed 6 hours to cool. If it fails to cool to less than 10°C (18 deg. F) above ambient temperature, the unit is declared dead and the appropriate error is generated.

When power is applied to the unit, operation begins with the use of one absorption unit. The air is monitored by the humidity sensor for a short time. The first absorption unit is taken off line and the other absorption unit is brought into service. If the first absorption unit was found to be “wet,” it is regenerated; if not, it is placed on standby and not regenerated. The second absorption unit is likewise tested. If it is found to be wet, the other absorption unit is brought back into use and the second unit is regenerated. The normal regeneration cycle is then entered. If both are found to be wet, operation continues with the second, the first is regenerated, and the dew point alarm is issued.

## **Maintenance**

### **Preventive Maintenance**

The ADH-2A COM requires no preventive maintenance. Replacement of the air pump after 10 years is recommended. Warning 13 appears when 8,000 hours has been accumulated on the pump. Replace sooner if the unit’s duty cycle is consistently above 10%. The pump has an air inlet filter which we recommend replacing every 2 years. We also recommend replacement of the absorption units every 15 years. While there is nothing to “wear out”, the desiccant will gradually lose efficiency due to atmospheric contamination.

### **Corrective Maintenance**

Verifying the performance of the ADH-2A COM requires special equipment, fixtures, and expertise. Please consult with Customer Service at Environmental Technology, Inc. before attempting to service or repair the ADH-2A COM.

## **Environmental Technology, Inc.**

**Safety Note:** *Servicing should be left to qualified personnel. The ADH-2A COM contains lethal voltages. Assume that all circuits are live. The unit may produce as much as 8 psig (55 kPa) under worse case failure. Vent the system to atmosphere before servicing pneumatic components.*

All fittings and hardware are standard American dimensions (inches). Use a solution of liquid dish detergent and water to locate air leaks. By convention, Absorption Unit 1 is the right hand absorption unit when viewed from the front of the unit.

**Warning:** *Do not apply power to the unit unless all internal connection have been made. Failure to do this may result in component destruction.*

It is best to return the entire unit to Environmental Technology for evaluation and repair, but we realize that is not always possible. If you can determine the problem and its resolution, replacement modules and assemblies can be obtained from Environmental Technology.

### **Returns and Replacement Parts Purchases**

Before returning the unit to Environmental Technology, Inc., obtain a return authorization number from our Customer Service Department between 8:00 AM and 5:00 PM EST (UTC minus five hours) at 219-233-1202 or 800-234-4239. With a return authorization number your ADH-2A COM can be returned. Use the original cushioning materials when packing the ADH-2A COM for shipment if possible.

## Troubleshooting

Problem	Action
Nothing works	<p><b>Verify the unit has power.</b></p> <ul style="list-style-type: none"> <li>Check the on-off switch and the power cable.</li> <li>Ensure power is available at the outlet.</li> <li>Verify proper voltage selected.</li> <li>Remove fuse module and inspect fuses.</li> </ul> <p><b>Move the unit to the bench and remove the top cover.</b></p> <ul style="list-style-type: none"> <li>Inspect fuse on Interface Circuit Board.</li> </ul> <p><b>Apply power.</b></p> <ul style="list-style-type: none"> <li>Verify power from Power Entrance Module to transformer with voltmeter.               <ul style="list-style-type: none"> <li>No power, replace Power Entrance Module.</li> </ul> </li> <li>Verify 24 VAC at the input to the rectifier.               <ul style="list-style-type: none"> <li>If none, replace transformer.</li> </ul> </li> <li>Verify 24 VDC at the output of the rectifier.               <ul style="list-style-type: none"> <li>If none, replace rectifier.</li> </ul> </li> <li>Replace Front Panel Circuit Board.</li> </ul>
<b>Low Pressure</b> (Alarm 01)	<p><b>Disconnect feed tube from air outlet.</b></p> <ul style="list-style-type: none"> <li>Pump should operate continuously.               <ul style="list-style-type: none"> <li>No pump operation.                   <ul style="list-style-type: none"> <li>Check pump electrical connections.</li> <li>Pump has failed.</li> <li>Either or both circuit boards have failed.</li> </ul> </li> </ul> </li> </ul> <p><b>Plug air outlet.</b></p> <ul style="list-style-type: none"> <li>Unit reaches correct operating pressure.               <ul style="list-style-type: none"> <li>Check communication equipment for leaks.</li> </ul> </li> <li>Continued low or no pressure.               <ul style="list-style-type: none"> <li>Check for stuck relief valve.</li> <li>Check internal air path for leaks or blockage.</li> <li>Check air flow through pump inlet filters.</li> <li>Verify integrity of pump diaphragms.</li> <li>Replace Front Panel Circuit Board.</li> </ul> </li> </ul>
<b>High Pressure</b> (Alarm 02)	<p><b>Disconnect feed tube from air outlet, allow pressure to reduce.</b></p> <p><b>Reconnect feed tube.</b></p> <ul style="list-style-type: none"> <li>Proper pressure attained               <ul style="list-style-type: none"> <li>Waveguide/coax too tightly sealed.</li> </ul> </li> <li>System returns immediately to overpressure condition.               <ul style="list-style-type: none"> <li>Replace Front Panel Circuit Board.</li> </ul> </li> </ul>

**Environmental Technology, Inc.**  
**Troubleshooting (Continued)**

<b>Problem</b>	<b>Action</b>
<b>Leaky System</b> (Warning 03)	<b>Disconnect feed tube from air outlet and plug.</b> <b>Allow unit to run for an hour or so and check duty cycle.</b> Low duty cycle. Check communication equipment for excessive leakage. High duty cycle ( above 50% ). Check for stuck relief valve. Check air path inside unit for leaks. Verify integrity of pump diaphragms. Replace Front Panel Circuit Board.
<b>High Temperature</b> (Warning 04)	<b>Inadequate ventilation around unit.</b>
<b>Low Temperature</b> (Warning 05)	<b>Inadequate or failed heating system in equipment room.</b> <b>Verify equipment room temperature above 40°F</b> Equipment room temperature above 40°F Replace front panel board
<b>Low Line Voltage</b> (Warning 06)	Check supplied power. Input power ok. Replace front panel board
<b>Absorption unit won't heat</b> (Alarms 07, 09)	<b>Absorption unit Check for Alarm 06 - Low line voltage.</b> <b>Check ambient temperature; too low makes heating difficult.</b> <b>Check for Dew Point Alarm (12).</b> If alarm has been issued, remove unit from service and allow to regenerate several times if <i>possible</i> .  <b>Move unit to bench and remove top cover.</b>  <b>Do not apply power.</b>  <b>Verify integrity of absorption unit leads.</b>  <b>Disconnect a heater lead and measure resistance through heater.</b> Should measure between 9 and 11 ohms. Replace absorption unit.

**Troubleshooting** *(Continued)*

<b>Problem</b>	<b>Action</b>
	<p><b>Disconnect a thermistor lead and measure resistance.</b> Should measure between .54 and .6 Megohm at 20°C. Replace Absorption unit</p> <p><b>If above resistance measurements are satisfactory, then either circuit board could be defective.</b> <i>Contact Customer Service.</i></p>
<p><b>Absorption unit won't cool</b> (Alarms 08,10)</p>	<p><b>Move unit to bench and remove top cover. With no power to unit, immediately feel absorption unit.</b></p> <p><b>Warm or hot to touch.</b> Replace Interface Circuit Board. Unit feels cool.</p> <p><b>Disconnect a thermistor lead and measure resistance.</b> Should measure between .54 and .6 Megohm at 20°C. Replace Absorption unit</p>
<p><b>Excessive Run Time</b> (Alarm 11)</p>	<p><b>Unit will shut down with this error. Reset unit by powering off and on, and then monitor for this condition.</b></p> <p><b>Disconnect feed tube from air outlet and plug outlet.</b> Pump continues to run. Check for stuck relief valve. Check air inlet filters for blockage. Inspect internal air path for leakage. Either circuit board could be defective. Unit reaches pressure and pump stops. Monitor pressure on front panel display. Rapid decrease. Check for stuck relief valve. Check internal air path for leaks. Pump diaphragms may be defective. Attains desired pressure and remains steady. Excessive leakage in communication equipment.</p>
<p><b>Dew Point Alarm</b> (Alarm 12)</p>	<p><b>Cycle through the Fault Codes; this alarm will usually occur in conjunction with other errors.</b></p>

**Environmental Technology, Inc.**  
**Troubleshooting** (*Continued*)

---

<b>Problem</b>	<b>Action</b>
Compressor time - out (Warning 13)	The air pump has accumulated 8,000 hours and should be replaced.
No Communications*	Verify proper address and speed selected on jumper strip. Verify correct connector wiring. Verify integrity of communications cable. Verify terminal set - up and operation. Replace Front Panel Circuit Board.

\* Master unit only.

## Appendix A. Specifications

Designation	ADH™-2A COM Automatic Air Dehydrator
Part Number	17696 (Rack Mount), 17846 (Wall Mount)
Dimensions	19" x 19" x 5.25" (48.3 cm x 48.3 cm x 13.3 cm) (Rack Mount) 19" x 21" x 5.25" (48.3 cm x 53.3 cm x 13.3 cm) (Wall Mount) 24" x 24" x 8" (60.0 cm x 60.0 cm x 20.3 cm) (NEMA)
Weight	Approximately 31.3 pounds (14.2 kg) (Rack and Wall Mount) Approximately 95.0 pounds (43.1 kg) (NEMA)
Storage temperature	-40°F to 150°F (-40°C to 60°C)
Operating temperature	32°F to 130°F (0°C to 55°C); NEMA: -40°F to 130°F (-40°C to 55°C)
Mounting method	Standard relay rack mount (3U) or wall mount
Air discharge pressure	0.5 psig (34.5 mbar)
Pressure range	0.25 to 0.5 psig (17.2 to 34.5 mbar)
Discharge port	1/4" hose barb (6.4 mm)
Number of discharge ports	1
Air pressure indication	Digital display (psig SI)
Relief valve operating pressure	1.8 psig (124 mbar)
Air discharge flow rate (max.)	14.2 cu. ft. / hr. (6.71 l/min.)
Maximum dew point	-40°F (-40°C)
Pneumatic safety	Pressure relief valve
Regeneration method	Automatic, demand
Power requirements	60 VA nominal, 146 VA maximum
Supply voltage	120/230 VAC, 50 or 60 Hz
Data displays	Pressure, temperature, flow rate, unit status, duty cycle, compressor time
Communications port	RS-422, 1200 or 9600 baud, 7 bit, even parity, 1 stop bit, DB-9 female connector
Alarm relay capacity	1 Amp @ 240 VAC
Relay connection	DB-15 female connector
Reliability	MTBF – more than 150,00 hours when maintaining a 5% or lower duty cycle. Higher duty cycles may shorten the MTBF.

## Appendix B. Alarms, Warnings and Status

### Display Meaning

---	No errors
A01	Low pressure alarm: Unit cannot attain desired pressure
A02	High pressure alarm: System pressure too high
03	Leaky system warning: Excessive duty cycle
04	High temperature warning: Ambient temperature over 150°F
05	Low temperature warning: Ambient temperature under 32°F
06	Low line voltage warning
A07	Absorption unit 1 unable to attain regeneration temperature
A08	Absorption unit 1 will not cool after regeneration
A09	Absorption unit 2 unable to attain regeneration temperature
A10	Absorption unit 2 will not cool after regeneration
A11	Excessive compressor operation: Reset by power off
A12	Dew point alarm: Possibility that the unit will not supply dry air
13	Air pump has accumulated 8,000 hours

### Status Interpretation

“o”	Absorption unit idle, ready to use (“I” if remote terminal)
“u”	Absorption unit in use
“r”	Absorption unit in regeneration
“F”	Absorption unit full, in need of regeneration
“d”	Absorption unit declared dead (Unable to regenerate)
“L”	Leaky system (with decimal point if regenerating)
“S”	System in standby (with decimal point if regenerating)

## Appendix C. Master/Slave Configuration

### Purpose

The master/slave configuration consists of connecting two ADH-2A COM automatic air dehydrators to the same system in order to provide redundancy and increase the system reliability.

### Description

The two ADH-2A COM air dehydrators in the master/slave configuration communicate with each other over an RS-422 interface. The interface cable connections is shown in Figure 6 and described in Table 1. The master and slave units must have the same baud rate and address jumpers set. It is recommended to use 9600 baud in the master/slave configuration. The ADH-2A COM master utilizes different firmware in this configuration. Be sure to specify master configuration when ordering. Also, be sure to specify if PC remote monitoring is required.

Under normal conditions, the master and slave unit will alternate control of air dehydration in the waveguide system, each being on line for 50 hours. When one unit is in control, the other will be in a standby mode. The standby mode is indicated by an S on the absorption unit state display.

There are three conditions that will cause an ADH-2A COM to relinquish control to the other unit. The three conditions are:

- 1.) Unit unable to perform air dehydration
- 2.) Unit unable to attain desired pressure
- 3.) Master/slave communication failure

Condition 1 would occur if both absorption units in the air dehydrator fail or an absorption unit has failed and the other needs to be regenerated. Once a unit has relinquished control for this condition, it will not get it back unless the condition goes away.

Condition 2 would exist if a unit runs for four hours without attaining the desired pressure. The unit declares itself leaky. This is indicated by an L on the status display. This is a permanent condition, unless the other unit also declares itself leaky. In this situation the master and the slave will attempt to pressurize the system together by running together. If the two units together are not able to maintain pressurization for four hours, they are both declared leaky and pressurization halts.

Condition 3 would occur if either the master or the slave does not receive a message within 15 minutes of the last one. If the master declares a communication failure (Alarm #14), it will attempt to alternate with the slave, each pressurizing for one pressure cycle. If the slave does not do its share during this alternation, the master will assume that it is dead and go to normal active mode. If the slave gets a communications failure and if it was in standby at the time, it will return to active mode and start pressurizing the waveguide. Only the master shows the alarm for a communication failure.

### Remote Terminal Communications

A remote terminal can also be installed to monitor the communication between the master and slave, but different cables and an interface box are required as shown in Figure 7. The terminal program will receive commands sent by the master to the slave. The terminal program should ignore all messages not beginning with an ACK.

**Environmental Technology, Inc.**

Every half second (normally) the master will send a status message to the remote terminal. These will normally alternate between the master's status and the slave status. The format of the message is exactly the same as the response to a hex 31 command on the slave ( see Communications section in this manual). The address used for the slave status message is the same as the master/slave address jumper setting, while the address for the master status message is one higher. The slave's status message is only sent to the remote terminal if the master can get it from the slave successfully. If the slave's status is not available, (master/slave communication failure) the slave status message will not be sent. In this situation the remote terminal will only get one message every second, and that will be the master's status. The master's status is always current, while the slave's status is 250 milliseconds old.

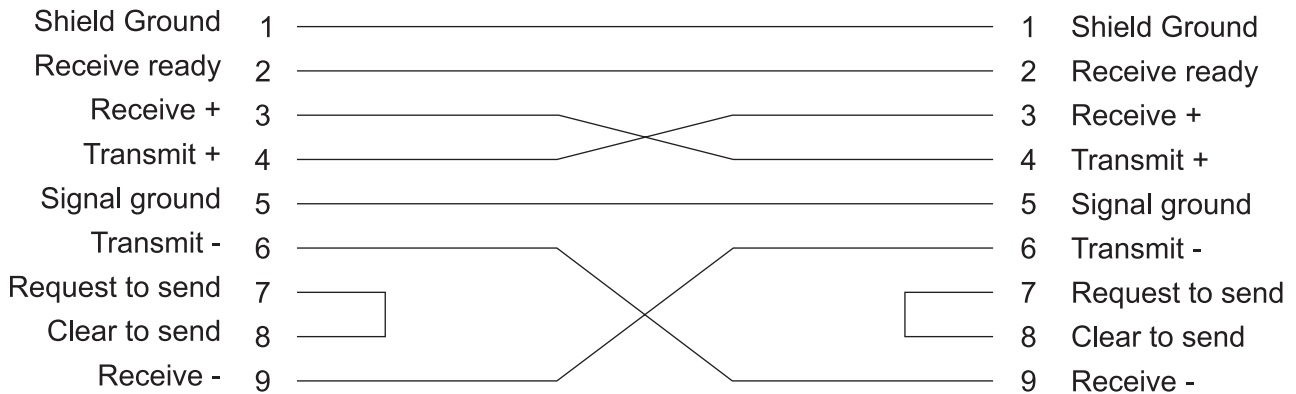

Figure 6. Master Slave interface cable diagram

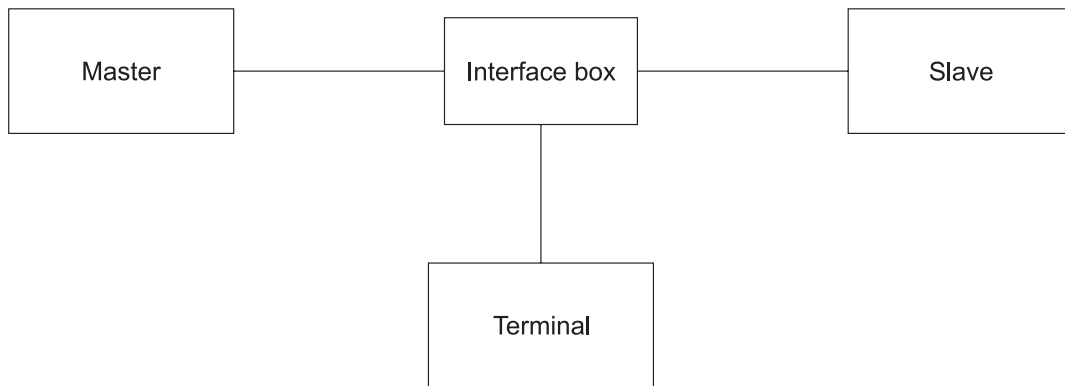

Figure 7. Master/Slave with remote terminal interconnection

## APPENDIX D. NEMA Configuration

### Purpose

The ADH-2A COM NEMA allows convenient outdoor mounting of an air dehydrator system, freeing up premium telecommunications equipment rack and wall space. This outdoor unit also provides a closer location to maximize effective pressurization of the waveguide or coaxial cable at remote locations. While the NEMA enclosure keeps out moisture, the temperature control system allows operation to -40°F (-40°C).

### Description

The ADH-2A COM NEMA consists of a wall mount configured ADH-2A COM air dehydrator mounted inside a NEMA 3R enclosure with a dedicated temperature control system allowing outdoor operation. A customer controlled thermostat is provided for exact temperature selection. The thermostat has an adjustment range of -10°F (-23°C) to 100°F (38°C). The thermostat is set at the factory for 40°F (4°C). There is also a temperature limit switch which is set for 120°F (49°C).

The ADH-2A COM NEMA input voltage is set at the factory at the time of order. The ADH-2A COM NEMA input voltage can be factory wired for 120 or 240 vac. A label is located near the power terminal block indicating the input voltage wired at the factory. If this unit is changed to another voltage, this label must be changed. Although instructions are included in this appendix for changing the input voltage in the field, it is **strongly recommended** that you contact customer service before any changes are made. Customer service is available between 8:00 a.m. and 5:00 p.m. EST (UTC minus 5 hours) at 219-233-1202 or 800-234-4239.

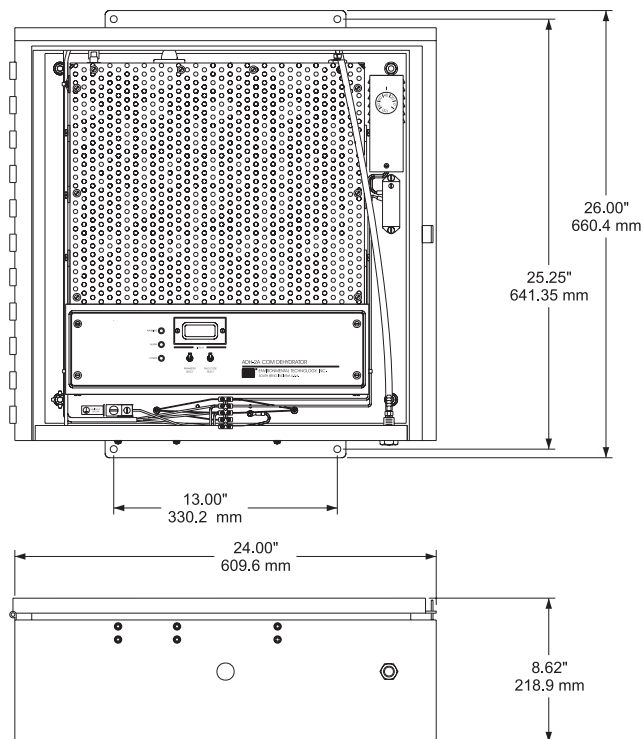

Figure 8. NEMA box mounting dimensions. (Front shown with cover removed)

### Installation

The following are suggested steps for installing the ADH-2A COM NEMA:

1. A suitable mounting area, 24" W x 26" L x 10" D (610 mm W x 660 mm L x 250 mm D), must be selected to mount the unit in a vertical manner. A wall such as reinforced concrete or steel plating should be used to support a static load of approximately 100 pounds. Use four appropriate 5/16" mounting hardware to fasten the unit to the support wall. Proper bolt size and depth is important for stable mounting.
2. Ensure the ADH-2A COM is correct for the input voltage that will be applied. A label was applied at the factory inside the enclosure next to the input power terminal block to indicate what voltage the unit was wired for at the factory.
3. The NEMA 3R enclosure shall be installed so the ADH-2A COM is perpendicular with the ground, and the terminal blocks for the electrical wiring are at the bottom.

## **Environmental Technology, Inc.**

4. The ADH-2A COM NEMA is permanently connected equipment and does not have an internal disconnect device. A readily accessible disconnect device, and short circuit and current protection shall be provided in the building installation.
5. A 7/8 inch hole is provided at the bottom of the enclosure for a conduit connection for the electrical wiring.
6. Connect the wires for the two alarm relays to the relay terminal blocks. Refer to the labels on the enclosure and the internal interconnect diagrams for further information.
7. Connect the input voltage wires to the input power terminal block. Refer to the label on the enclosure and the internal interconnect diagrams for further information.
8. Connect supply tubing to the 1/8" NPT female connection at bottom of NEMA enclosure.

## **Input Voltage**

**Warning:** *There are lethal voltages present inside the case of the ADH-2A COM. Service should be performed by qualified personnel only.*

The ADH-2A COM NEMA input voltage is configured at the factory. A label near the power terminal block indicates the input voltage set at the factory. It is **strongly recommended** that the input voltage be configured at the factory. However, if the input voltage needs to be changed, the following procedure should be followed:

1. Ensure there is no power applied to the unit.
2. Disconnect the wires from the alarm relay terminal blocks.
3. Disconnect the input voltage wires from the input voltage terminal block.
4. Disconnect the silicone tubing from the bulkhead fitting.
5. Remove the ten screws holding the air dehydrator cover. This is required in order to have an area to grasp when lifting out of enclosure. Save screws and cover in convenient place for reassembly.
6. Remove four nuts holding mounting plate to the NEMA enclosure. Save nuts in convenient place for reassembly.
7. Carefully lift the assembly out of the enclosure.
8. Remove the power select fuse module from the back of the air dehydrator and rotate to the other input voltage.
9. Reinstall power select fuse module.
10. Reinstall power plug.
11. Rewire the heaters for the new voltage. Refer to the appropriate interconnect diagram.
12. Carefully reinstall the assembly into the enclosure.
13. Reinstall the four nuts holding the mounting plate to the NEMA enclosure.
14. Reinstall the air dehydrator cover using the ten screws previously removed.

15. Reconnect silicone tubing to the bulkhead fitting.
16. Reconnect the alarm relay wires to the terminal blocks. Refer to the interconnect diagram and terminal block labels.
17. Reconnect the input voltage wires to the terminal block. Refer to the interconnect diagram and terminal block label.
18. Replace the label indicating the input voltage set at the factory with one indicating the new input voltage configuration.

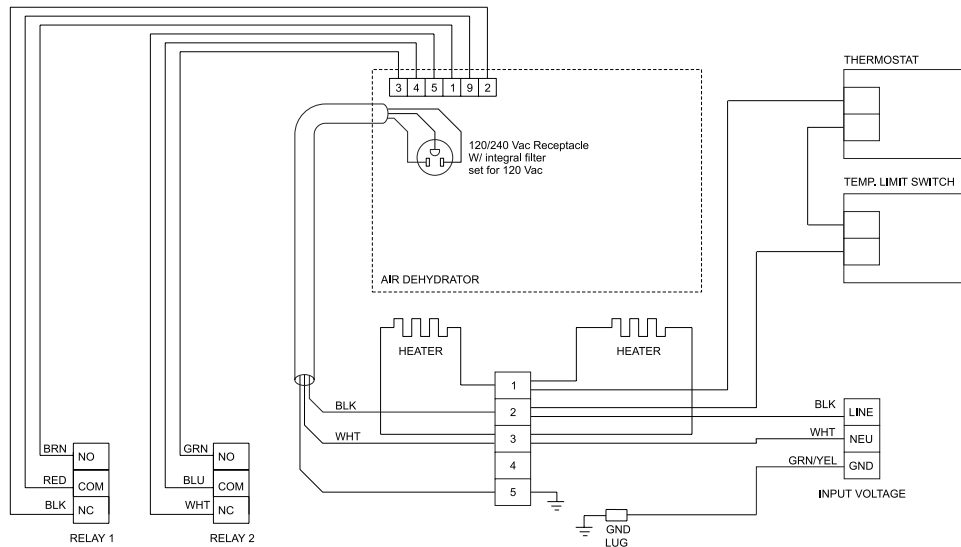

Figure 9. Wiring for 120 Vac NEMA.

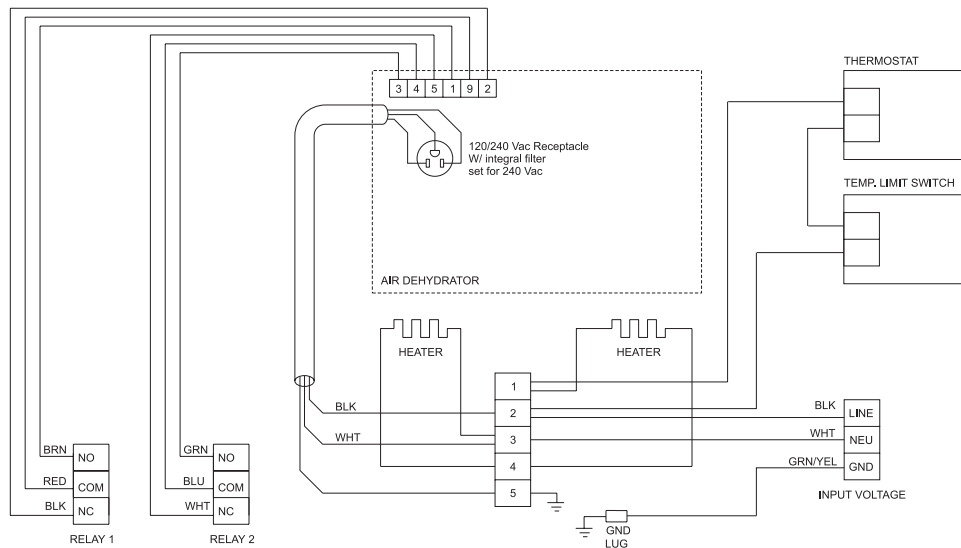

Figure 10. Wiring for 240 Vac NEMA.

**Environmental Technology, Inc.**