

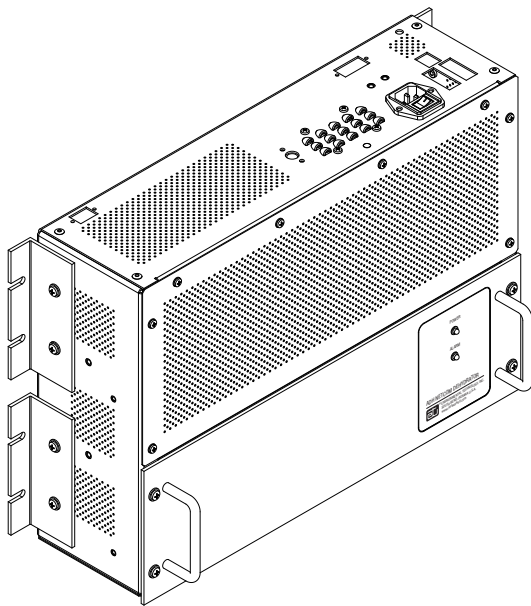

FEATURES & BENEFITS

- Provides dry pressurized air to ensure signal quality of antenna waveguide and dielectric coaxial cable
- Highly configurable to meet the needs of wide ranging applications
- Field programmable operating pressure range from 0.10 psig to 7.50 psig (7mbar to 517mbar)
- Brushless dual-diaphragm compressor for long life
- Future-proof software based features allow updates and upgrades while in service
- Remote monitoring and control with web interface or SNMP
- Configurable Master/Slave operations
- Ethernet, RS-422/485, RS-232 and alarm relay outputs for compatibility with nearly any system
- Optional front panel with display allows for IP configuration and status monitoring when no network is available
- Simple power connections for 100-240 VAC or $\pm 20-75$ VDC
- Small, light weight chassis with multiple mounting options makes installation easy
- Low energy use minimizes lifetime operational costs
- Quiet operation



Wall Mount

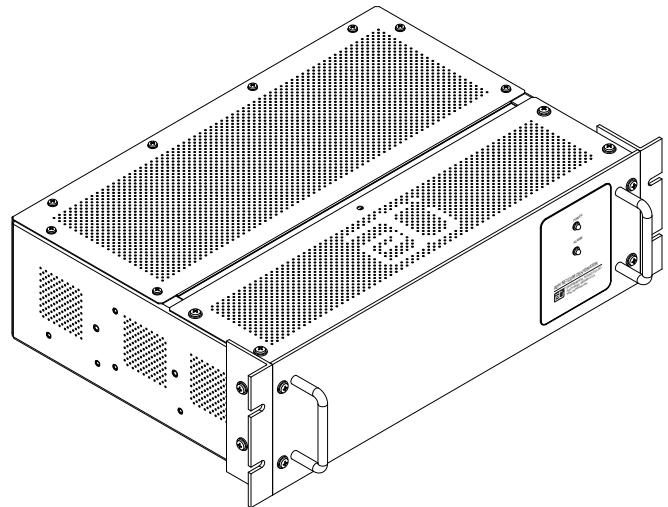

Rack Mount

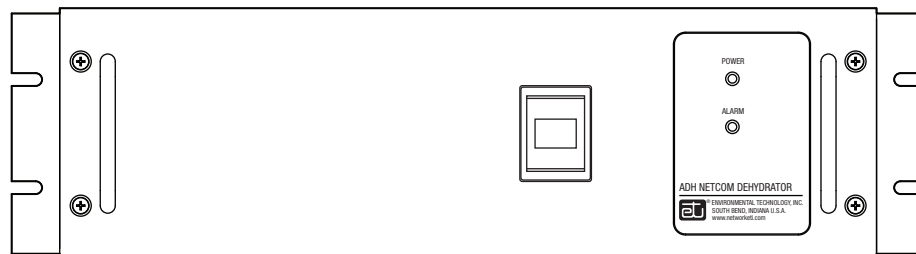

Optional Front Panel with Display

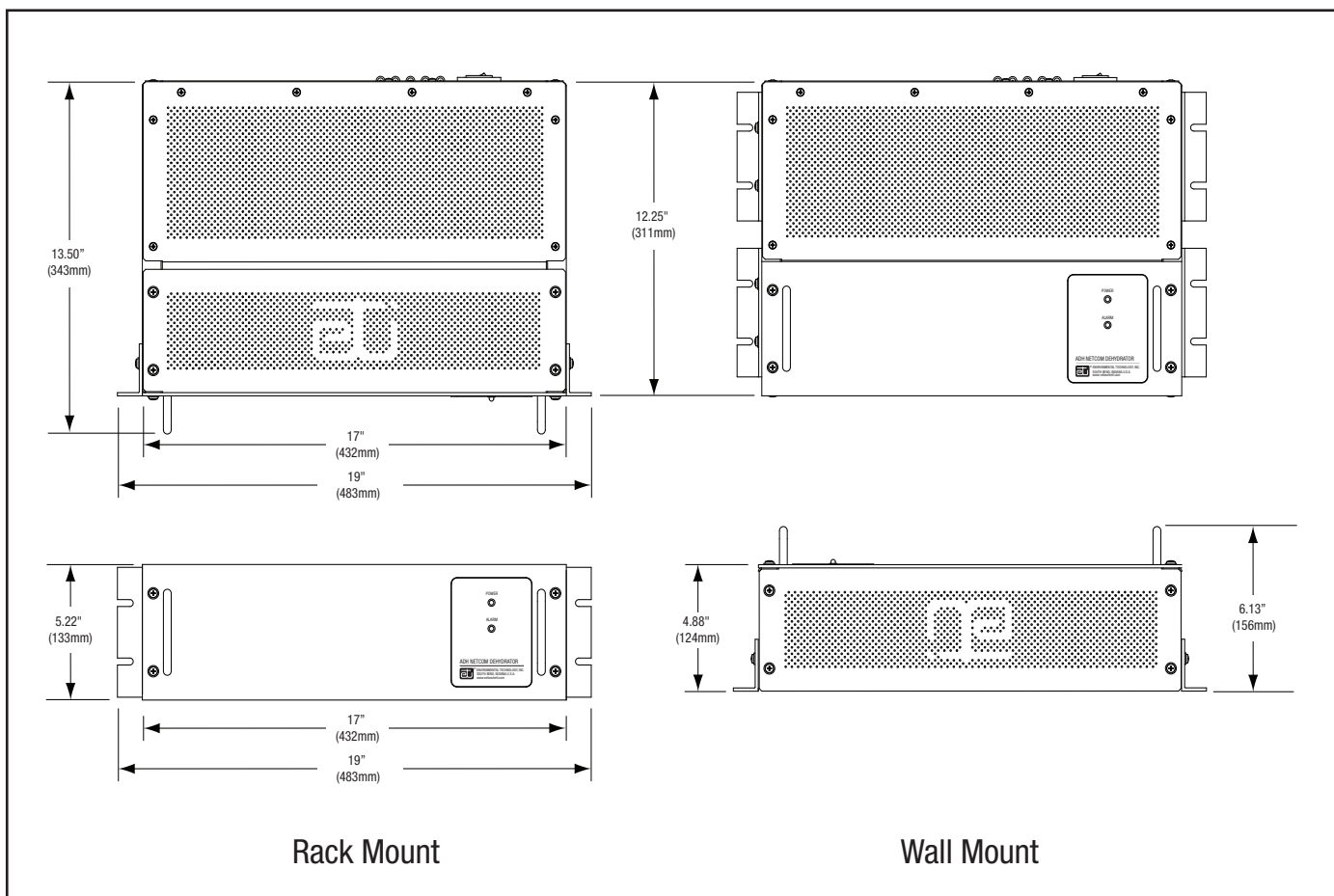

Rack Mount

Wall Mount

DESCRIPTION

The ADH NETCOM automatic dehydrator supplies low pressure dry air to keep waveguide and coaxial cable dry. Output pressure is field configurable between 0.10 psig and 7.50 psig (7mbar - 517mbar) in 0.01 psig (0.67mbar) increments. Factory default pressure is 0.5 psig (34.5mbar). Operational monitoring and alarms are software based making them highly configurable in the field. Future software features can be installed while in service over the internet or local Ethernet network.

The ADH NETCOM automatic dehydrator is Ethernet network ready. Units can be configured and monitored using either built-in SNMP support or the web interface. Legacy system support is provided via RS-422/485 or RS-232 interfaces. Three programmable alarm relays are also

included. User display shows output pressure, duty cycle, temperature, compressor hours and air drying canister status.

The ADH NETCOM automatic dehydrator uses a brushless dual-diaphragm pump for long life. Dehydrator operates with exceptionally low noise and vibration levels. The air drying canisters use aluminum oxide desiccant for high efficiency. The humidity sensor signals for regeneration based upon current dew point rather than at fixed time intervals for additional energy savings and long desiccant life.

The ADH NETCOM automatic dehydrator requires only 5-1/4" (3-U) of rack space and is just 12" (304.8mm) deep. Mounting hardware allows for flexible installation options including dual- and single-post rack mounting and wall mounting. The standard unit

weighs just 16 lbs (7.26 kg).

The ADH NETCOM automatic dehydrator operates from 100-240 VAC, 50/60 Hz. Optional units are also available at $\pm 20-75$ VDC. The dehydrator consumes a maximum of 150 watts during regeneration and about 40 watts otherwise. Heat dissipated is up to 512 BTU/hr during regeneration and about 136 BTU/hr otherwise. The ADH NETCOM creates an exceptionally low heat load for an automatic dehydrator.

An optional front panel with display allows for IP configuration and status monitoring when no network is available.

For complete information describing application, installation and features, please contact ETI Customer Service or visit www.networketi.com.

SPECIFICATIONS

General

Approvals

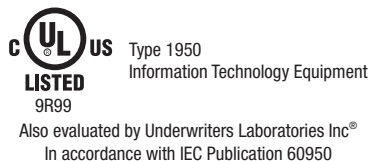

Regeneration Method	Automatic, demand
Maximum dew point	-40° F/C

Enclosure

Dimensions	17" × 12" × 5-1/4" (432mm × 305mm × 133mm)
Weight	16 lbs (7.26 kg)
Mounting	Dual-post rack, flush mounted Single-post rack, center mounted Wall mounted

Power

Supply	100-240 VAC, 50/60 Hz ±20-75 VDC
Maximum current	1.0 Amps at 100 V
Power usage	40 W typical, 150 W max
Heat dissipation	136 BTU/hr typical @40 W, 512 BTU/hr max @150 W

Output

Flow rate	25.4 scfh (12 lpm)
Maximum pressure	7.5 psig (517mbar)
Internal safety relief valve	8 psig (552mbar)
Discharge port	1/8" NPT 3/8" or 1/4" hose barb (both included)
Display units	SI (millibars); English (psig), default

Control

Protocols	HTTP (Web Interface), SNMP, UDP, TFTP
Maximum pressure	Configurable Range: 0.20 psig - 7.5 psig (14mbar - 517mbar), Default: 0.50 psig (34.5mbar)
Minimum pressure	Configurable Range: 0.10 psig - 7.4 psig (7mbar - 510mbar), Default: 0.30 psig (21mbar)
Low pressure alarm level	User Configurable, Default: 0.15 psig (10mbar)
High pressure alarm level	User Configurable, Default: 1.5 psig (103.5mbar)
Alarm relays	Contact Type - Form C, SPDT, reverse acting Ratings - 0.25 Amps @ 60 V User Configurable, Defaults - Alarm Relay 1: Summary Alarm, Alarm Relay 2: Low Pressure Alarm, Alarm Relay 3: Over Pressure Alarm
Duty cycle alarm	User Configurable, Default: 50%
Master/Slave configuration	User Configurable, Default: Standard/Slave

Environmental

Operating temperature	32°F to 130°F +/-2°F (0°C to 55°C +/-1°C)
Storage temperature	-40°F to 150°F (-40°C to 60°C)

ORDERING INFORMATION

Order Number	Description
23437	ADH NETCOM Automatic Dehydrator, 100-240 VAC
24658	ADH NETCOM Automatic Dehydrator, 100-240 VAC with Display
23242	ADH NETCOM Automatic Dehydrator, \pm 20-75 VDC
24659	ADH NETCOM Automatic Dehydrator, \pm 20-75 VDC with Display

LIMITED WARRANTY

ETI's two year limited warranty covering defects in workmanship and materials applies. Contact Customer Service for complete warranty information.

DISCLAIMER

Environmental Technology, Inc. makes no representations or warranties, either expressed or implied, with respect to the contents of this publication or the products that it describes, and **specifically disclaims any implied warranties of merchantability or fitness for any particular purpose**. Environmental Technology, Inc. reserves the right to revise this publication, and to make changes and improvements to the products described in this publication, without the obligation of Environmental Technology, Inc. to notify any person or organization of such revisions, changes or improvements.